

# VUpoint

## Pan/Tilt 2MP Wi-Fi Camera



Model: RVCM61H1700B



**Quick Guide**

**Language**

**Page**



3



7



11



15



## IP Camera Components

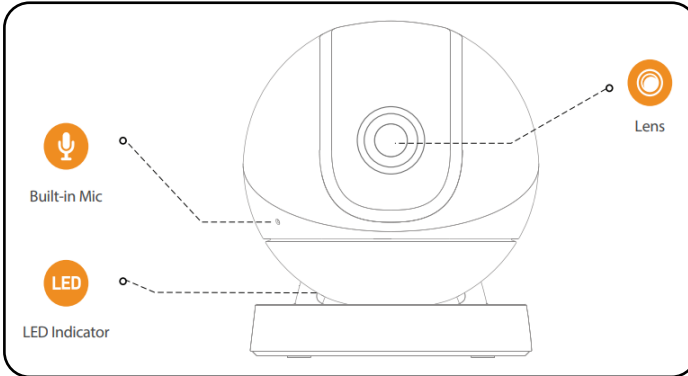

**Note:** For reset (used to return the camera settings to factory default mode), long press the Reset/WPS button for 8 seconds; the light turns off.

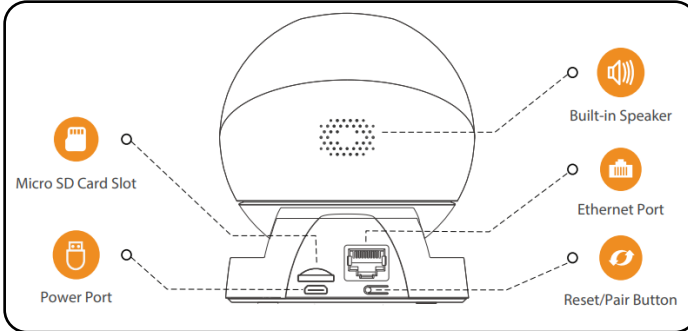

Indication	Status
Green light slow flashing	IP Camera is not connected to the RISCO Cloud. Please check for internet connection.
Green light steady on	IP Camera is successfully connected to the RISCO Cloud.

# Ceiling Mounting (Optional)

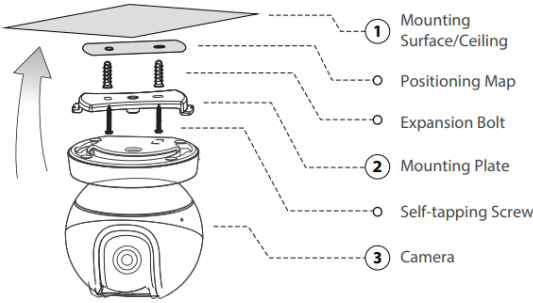

# Defining IP Camera Settings

## Step 1

Connect one end of the network cable (LAN) to the camera Ethernet port and the other side to your router. Power up the camera with an appropriate power supply.

## Step 2

If the camera is connected to a VUpoint NVR, refer to the VUpoint Network Video Recorder Installation Guide for further installation instructions. If the camera is installed as a stand-alone camera (without NVR connection), follow steps 3 – 6 below.

## Step 3

Log into your Installer Admin Application and select a Site. Click Network Cameras → click

[+ Add New Camera](#) and then enter the definitions into the provided fields.

The screenshot shows the 'ADD NEW CAMERA' form with the following fields and annotations:

- CAMERA NAME:** Camera 1
- CAMERA TYPE:** RISCO (Selected), Non RISCO Cameras (0/0)
- CAMERA ID:** (Empty field)
- Buttons:** Next, Cancel

Annotations:

- MAC address → CAMERA ID
- Click when done → Next
- Define Camera Settings → CAMERA NAME and CAMERA TYPE

## Step 4

Click to establish Wi-Fi connection

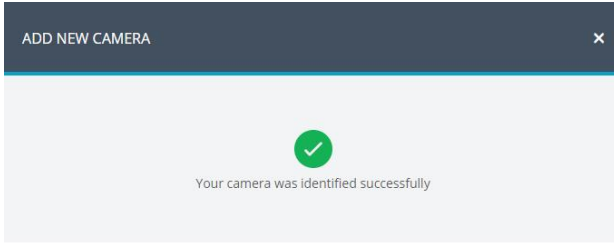

Would you like to connect it to your Wi-Fi network?

Connect to Wi-Fi

Not Now

## Step 5

If your network is password protected, enter a password into the displayed password field

Click for Wi-Fi network connection

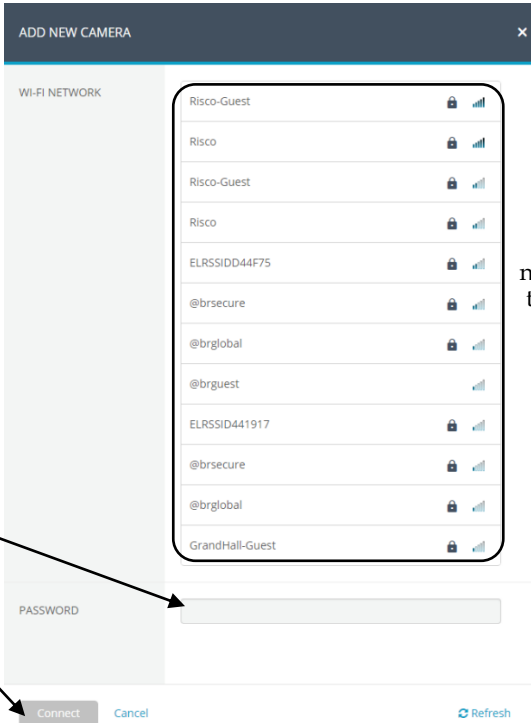

Select a wireless network from the available list

## Step 6



Your camera is ready for use

You can disconnect the camera from the router and install it in your preferred location

Click OK



## Product Specifications

Parameter	Description
Image Sensor	1/2.7" 2Megapixel progressive CMOS
IR Distance	10 m
Focal Length	3.6 mm
Pan / Tilt	355° Pan & 0~90° Tilt
Power Supply	5V / 2A DC
Power Consumption	<7.5W
Wi-Fi Power Output	20dBm max.
Wi-Fi Frequency	2.4 GHz

**Note:** For Australia, New Zealand and USA, the approved AC/DC adapter shall be used according to the country's regulations.

## Composants de la caméra IP

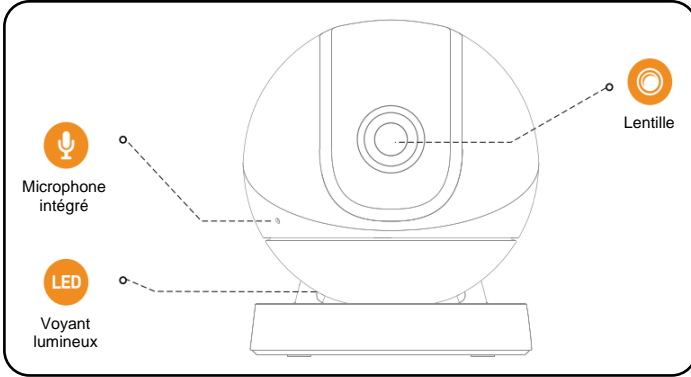

**Remarques :** Pour réinitialiser la caméra (c'est-à-dire rétablir ses paramètres par défaut), appuyez sur le bouton Reset/WPS pendant 8 secondes ; le voyant s'éteint.

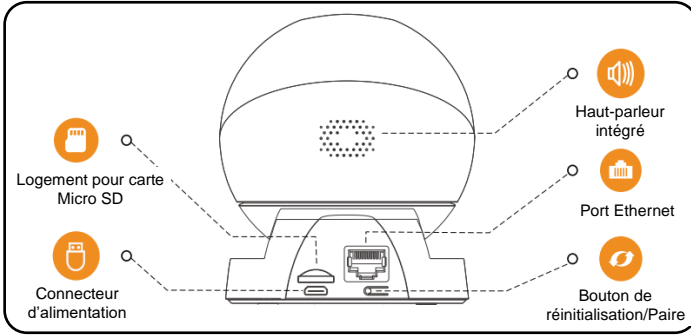

Indication	État
Voyant vert clignotant lentement	La caméra IP n'est pas connectée au RISCO Cloud. Vérifiez la connexion Internet.
Voyant vert allumé normalement	La caméra IP a bien été connectée au RISCO Cloud.

## Montage au plafond (en option)

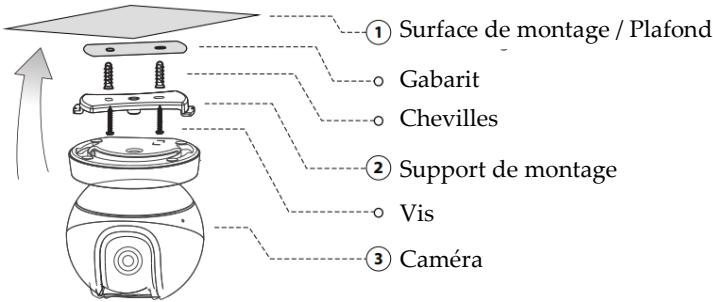

## Définition des paramètres de la caméra IP

### Étape 1

Raccordez l'une des extrémités du câble réseau (LAN) au port Ethernet de la caméra, et l'autre extrémité à votre routeur. Alimentez la caméra avec une alimentation appropriée.

### Étape 2

Si la caméra est raccordée à un enregistreur vidéo réseau (NVR) VUpoint, consultez le guide d'installation du NVR VUpoint pour obtenir des instructions d'installation. Si la caméra est installée en tant que dispositif autonome (sans connexion à un NVR), suivez les étapes 3 à 6 ci-dessous.

### Étape 3

Connectez-vous à votre compte Cloud installateur et sélectionnez un site. Cliquez sur Caméras IP, cliquez sur [+ Nouvelle Caméra](#), puis renseignez les champs requis.

Adresse MAC

Cliquez lorsque vous avez terminé

Définissez les paramètres de la caméra

Suivant Annuler



## Étape 4

Cliquez pour établir la connexion Wi-Fi

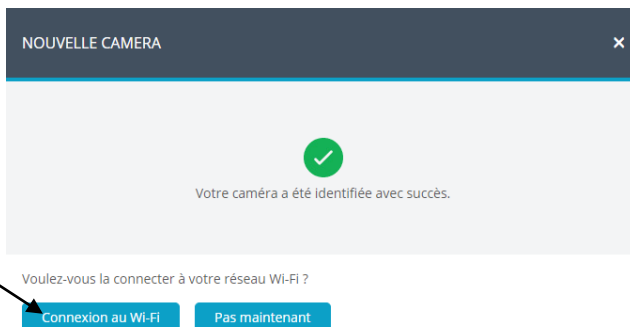

## Étape 5

Si votre réseau est protégé par mot de passe, saisissez le mot de passe dans le champ prévu à cet effet

Cliquez pour établir la connexion au réseau Wi-Fi

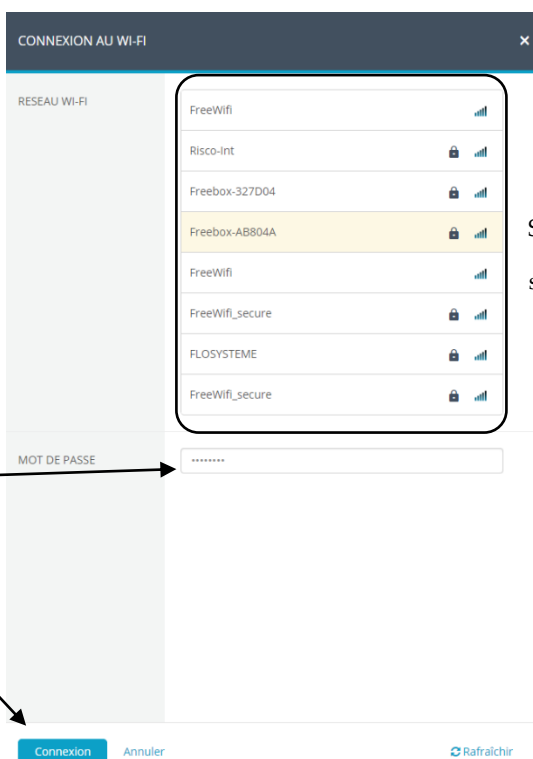

Sélectionnez un réseau sans fil dans la liste

## Étape 6

CONNEXION AU WI-FI



Votre caméra est prête à être utilisée.

Vous pouvez déconnecter la caméra du routeur et l'installer à l'emplacement souhaité.

Cliquez sur  
OK



OK

## Spécifications du produit

Paramètre	Description
Capteur d'image	CMOS 1/2.7" de 2 Mégapixel progressif
Distance IR	10 m
Focale	3.6 mm
Pan / Tilt	355° Pan & 0~90° Tilt
Alimentation	5V / 2A DC
Consommation	<7.5W
Puissance disponible Wi-Fi	20dBm max.
Fréquence Wi-Fi	2.4 GHz

## Componentes de la cámara IP

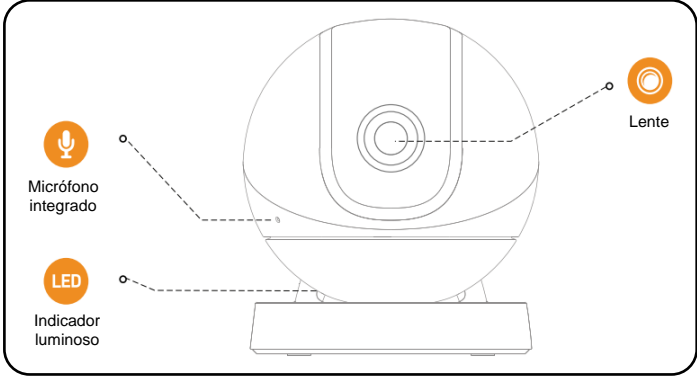

**Nota:** Para realizar un Reset (restaurar los ajustes de fábrica de la cámara), mantenga presionado el botón Reset/WPS durante 8 segundos y la luz se apagará.

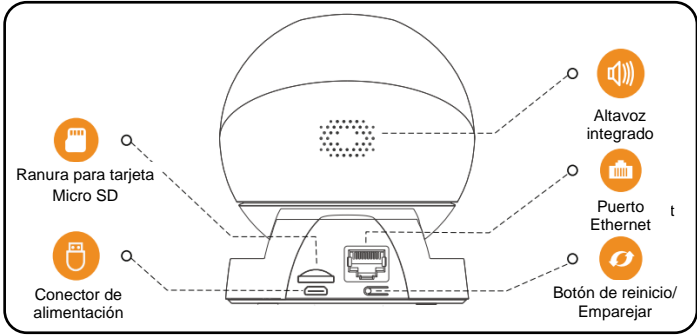

Indicación	Significado
Verde con parpadeo lento	La cámara IP no está conectada a RISCO Cloud. Compruebe la conexión a Internet.
Verde normalmente encendido	La cámara IP está conectada correctamente a RISCO Cloud.

## Montaje en techo (opcional)

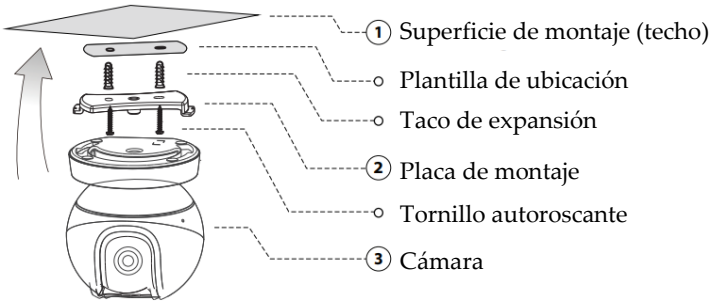

## Definiendo la configuración de la cámara IP

### Paso 1

Conecte un extremo del cable de red (LAN) al puerto Ethernet de la cámara y el otro extremo al router.

### Paso 2

Si la cámara está conectada a un NVR de VUpoint, consulte la Guía del grabador de vídeo en red (NVR) de VUpoint para ver más instrucciones de instalación. Si la cámara está instalada como cámara independiente (sin conexión NVR), siga los pasos 3-6 a continuación.

### Paso 3

Conéctese a la aplicación de administración del instalador y seleccione un sitio. Pulse en Cámaras IP → pulsar **+ Añadir una Nueva Cámara** y, a continuación, introduzca las definiciones en los campos correspondientes.

Interfaz de configuración de una cámara IP. El título de la ventana es "AÑADIR UNA NUEVA CÁMARA".

Campos de configuración:

- NOMBRE DE LA CÁMARA:
- TIPO DE CÁMARA:  RISCO  No-RISCO (2/5) ⓘ
- RISCO P2P:
- ID DE LA CÁMARA ⓘ:

Botones:

Etiquetas de anotación:

- Dirección MAC (punto de información ⓘ)
- Pulse cuando haya terminado (punto de información ⓘ)
- Defina la configuración de la cámara (punto de información ⓘ)

## Paso 4

Pulse para establecer la conexión Wi-Fi

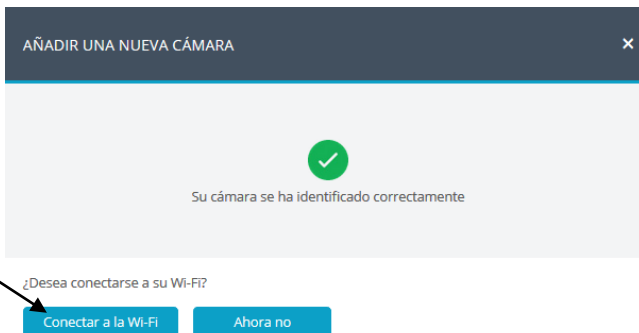

## Paso 5

Si la red está protegida con contraseña, introduzca una contraseña en el campo de contraseña

Pulse para establecer la conexión de red Wi-Fi

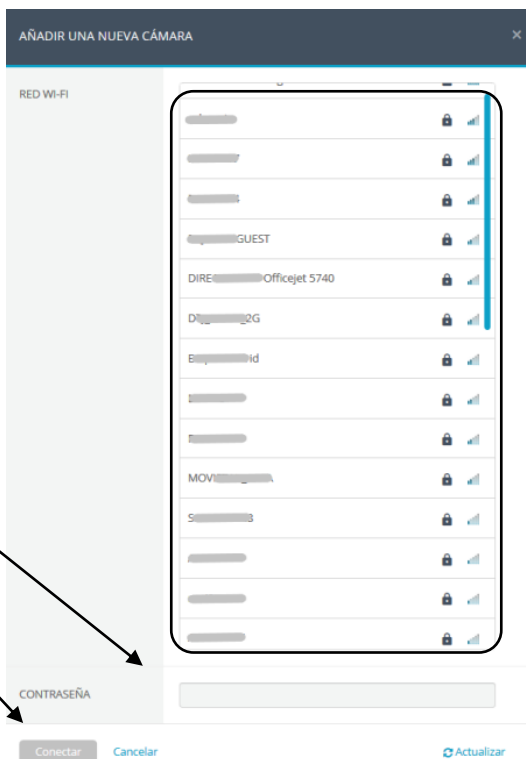

Seleccione una red inalámbrica de la lista

## Paso 6

AÑADIR UNA NUEVA CÁMARA



Su cámara está lista para usar

Puede desconectar la cámara del router e instalarla en su ubicación deseada

Pulse OK

OK

## Especificaciones del producto

Parámetro	Descripción
Sensor de imagen	1/2.7" 2Megapixel CMOS progresivo
Distancia IR	10 m
Distancia focal	3.6 mm
Pan / Tilt	355° Pan & 0~90° Tilt
Fuente de alimentación	5V / 2A DC
Consumo de energía	<7.5W
Salida de alimentación Wi-Fi	20dBm max.
Frecuencia Wi-Fi	2.4 GHz



## Componenti della telecamera IP

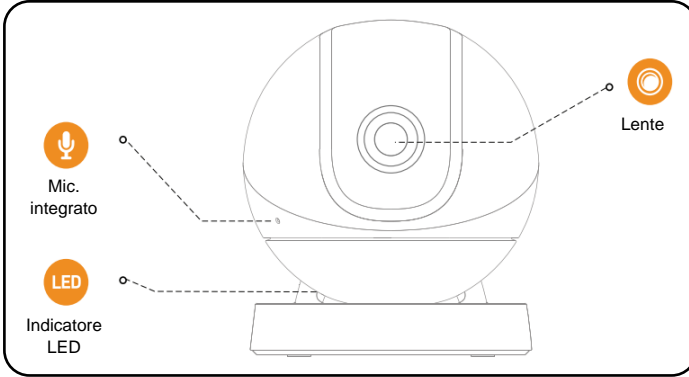

**Nota:** Per il reset (usato per tornare ai valori di fabbrica), premere il tasto Reset/WPS per 8 secondi; l'indicatore luminoso si spegnerà.

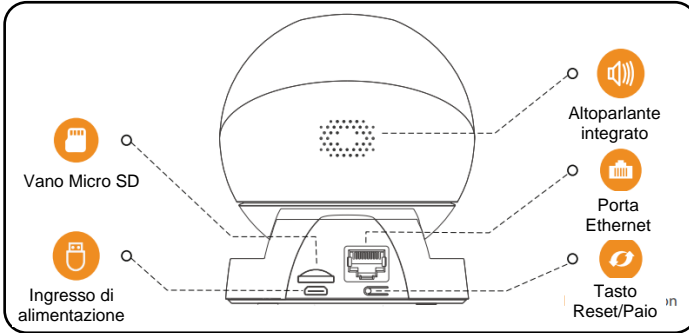

Stato LED	Significato
Lampeggio lento del LED verde	La telecamera non è connessa al cloud RISCO. Controllare la connessione internet.
LED verde accesa	La telecamera è connessa al cloud RISCO.

## Installazione a soffitto (opzionale)

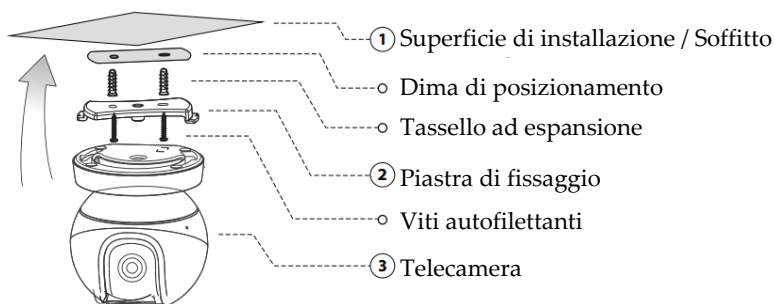

## Configurazione parametri telecamera IP

### Passo 1

Collegare un cavo LAN alla porta ethernet della telecamera e con l'altro capo del cavo collegarsi al router. Alimentare la telecamera con un alimentatore appropriato.

### Passo 2

Se la videocamera è collegata a un NVR VUpoint, consultare la Guida all'installazione del videoregistratore di rete VUpoint per ulteriori istruzioni di installazione. Se la videocamera è installata come videocamera indipendente (senza connessione NVR), seguire i passaggi da 3 a 6 seguenti.

### Passo 3

Accedere all'area Tecnica Installatore del cloud e seleziona un sito. Fare clic su Telecamera, cliccare su [+ Aggiungi telecamera](#), quindi inserire i dati nei campi visualizzati.

Lo screenshot mostra l'interfaccia "AGGIUNGI TELECAMERA" con i seguenti campi e controlli:

- NOME TELECAMERA:** Campo di testo con il valore "Telecamera 1".
- TIPO TELECAMERA:** Pulsanti radio per "RISCO" (selezionato) e "NON RISCO (0/0)".
- RISCO P2P:** Menu a tendina.
- ID TELECAMERA:** Campo di testo vuoto.

Altri elementi visibili:

- Un pulsante "+ Aggiungi telecamera" in alto a sinistra.
- Un pulsante "Successivo" e un pulsante "Annulla" in basso.
- Un'etichetta "Indirizzo MAC" con una freccia che punta verso il campo "ID TELECAMERA".
- Un'etichetta "Cliccare appena finito" con una freccia che punta verso il pulsante "Successivo".
- Un'etichetta "Definire i parametri telecamera" con tre frecce che puntano ai campi "NOME TELECAMERA", "TIPO TELECAMERA" e "ID TELECAMERA".



#### Passo 4

Cliccare qui per connettersi ad una rete WiFi

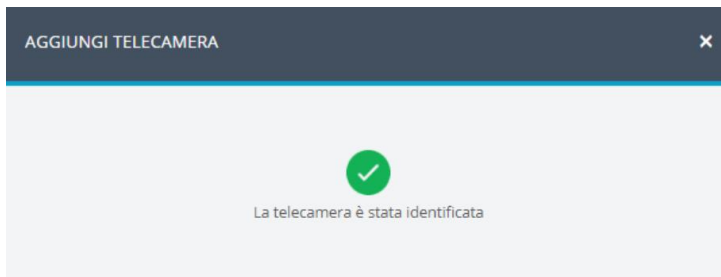

Desideri connettere una rete WiFi ?

Connetti WiFi

Non ora

#### Passo 5

Inserire la password della rete WiFi, se protetta e cliccare su Connetti

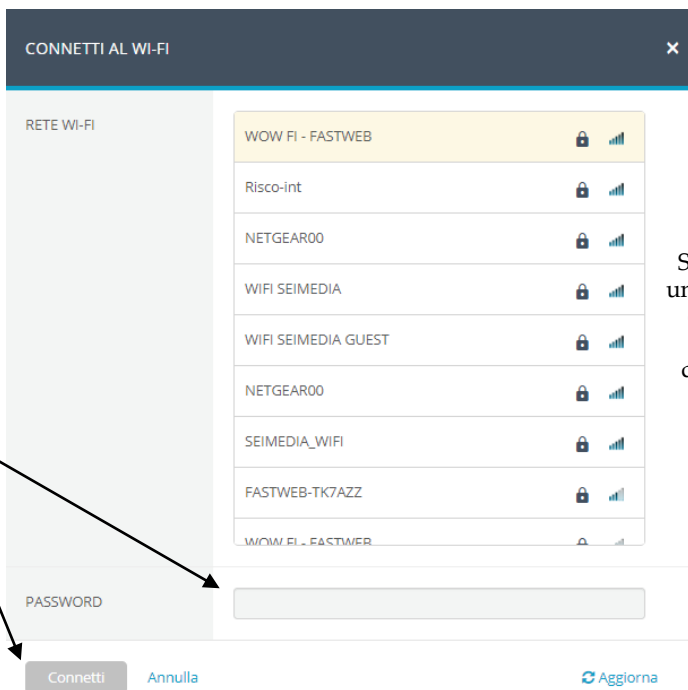

Selezionare una rete WiFi dalla lista delle reti disponibili

## Passo 6



Cliccare  
su OK



La tua telecamera è pronta per essere utilizzata. Scollega la telecamera dal router e installala nella posizione stabilita

OK

## Specifiche Tecniche

Parametro	Descrizione
Sensore video	1/2.7" 2Megapixel progressivo CMOS
Distanza a IR	10 m
Lunghezza Focale	3.6 mm
Pan / Tilt	355° Pan & 0-90° Tilt
Alimentatore	5V / 2A DC
Assorbimento	<7.5W
Potenza trasmessa Wi-Fi	20dBm max.
Frequenza Wi-Fi	2.4 GHz

### **UKCA and CE RED Compliance Statement:**

Hereby, RISCO Group declares that this equipment is in compliance with the essential requirements of the UKCA Radio Equipment Regulations 2017 and CE Directive 2014/53/EU.

For the UKCA and CE Declaration of Conformity please refer to our website: [www.riscogroup.com](http://www.riscogroup.com)

### **Rapport de Conformité de RED:**

Par la présente, RISCO Group, déclare cet équipement est en conformité aux conditions essentielles et à d'autres dispositions appropriées de la directive 2014/53/EU. Vous pouvez trouver la copie complète de la déclaration de conformité à la directive 2014/53/EU sur notre site web, à l'adresse suivante : [www.riscogroup.com](http://www.riscogroup.com).

### **Declaración de Conformidad RED :**

Por la presente, RISCO Group declara que este equipo cumple con los requisitos esenciales y otras disposiciones relevantes de la Directiva 2014/53/EU. Para la Declaración de Conformidad CE, por favor diríjase a nuestra web: [www.riscogroup.com](http://www.riscogroup.com).

### **Dichiarazione di Conformità RED:**

La sottoscritta RISCO Group, dichiara sotto la propria responsabilità che questo prodotto è conforme ai requisiti essenziali e alle altre rilevanti disposizioni della Direttiva Europea 2014/53/EU.

Per le Dichiarazioni di Conformità CE, visitate il nostro sito web: [www.riscogroup.com](http://www.riscogroup.com)

### **FCC ID: 2AVYF-IPC-AX6L**

This device complies with part 15 of the FCC Rules. Operation is subject to the following two conditions:

- (1) This device may not cause harmful interference, and
- (2) This device must accept any interference received, including interference that may cause undesired operation.

Changes or modifications to this equipment which are not expressly approved by the party responsible for compliance (RISCO Group's.) could void the user's authority to operate the equipment.

#### **FCC Note**

This equipment has been tested and found to comply with the limits for a Class B digital device, pursuant to part 15 of the FCC Rules.

These limits are designed to provide reasonable protection against harmful interference in a residential installation. This equipment generates uses and can radiate radio frequency energy and, if not installed and used in accordance with the instructions, may cause harmful interference to radio communications.

However, there is no guarantee that interference will not occur in a particular installation. If this equipment does cause harmful interference to radio or television reception, which can be determined by turning the equipment on and off, the user is encouraged to try to correct the interference by one or more of the following measures:

- ✦ Reorient or relocate the receiving antenna.
- ✦ Increase the separation between the equipment and the receiver.
- ✦ Connect the equipment into an outlet on to a different circuit from that to which the receiver is connected.
- ✦ Consult the dealer or an experienced radio/TV technician for help.

## **Standard Limited Product Warranty (“Limited Warranty”)**

RISCO Ltd. (“RISCO”) guarantee RISCO’s hardware products (“Products”) to be free from defects in materials and workmanship when used and stored under normal conditions and in accordance with the instructions for use supplied by RISCO, for a period of (i) 24 months from the date of delivery of the Product ( the “Warranty Period”). This Limited Warranty covers the Product only within the country where the Product was originally purchased and only covers Products purchased as new.

**Contact with customers only.** This Limited Warranty is solely for the benefit of customers who purchased the Products directly from RISCO or from an authorized distributor of RISCO. RISCO does not warrant the Product to consumers and nothing in this Warranty obligates RISCO to accept Product returns directly from end users who purchased the Products for their own use from RISCO’s customer or from any installer of RISCO, or otherwise provide warranty or other services to any such end user directly. RISCO’s authorized distributor or installer shall handle all interactions with its end users in connection with this Limited Warranty. RISCO’s authorized distributor or installer shall make no warranties, representations, guarantees or statements to its end users or other third parties that suggest that RISCO has any warranty or service obligation to, or any contractual privity with, any recipient of a Product.

**Remedies.** In the event that a material defect in a Product is discovered and reported to RISCO during the Warranty Period, RISCO shall accept return of the defective Product in accordance with the below RMA procedure and, at its option, either (i) repair or have repaired the defective Product, or (ii) provide a replacement product to the customer.

**Return Material Authorization.** In the event that you need to return your Product for repair or replacement, RISCO will provide you with a Return Merchandise Authorization Number (RMA#) as well as return instructions. Do not return your Product without prior approval from RISCO. Any Product returned without a valid, unique RMA# will be refused and returned to the sender at the sender’s expense. The returned Product must be accompanied with a detailed description of the defect discovered (“Defect Description”) and must otherwise follow RISCO’s then-current RMA procedure published in RISCO’s website at [www.riscogroup.com](http://www.riscogroup.com) in connection with any such return. If RISCO determines in its reasonable discretion that any Product returned by customer conforms to the applicable warranty (“Non-Defective Product”), RISCO will notify the customer of such determination and will return the applicable Product to customer at customer’s expense. In addition, RISCO may propose and assess customer a charge for testing and examination of Non-Defective Product.

**Entire Liability.** The repair or replacement of Products in accordance with this Limited Warranty shall be RISCO’s entire liability and customer’s sole and exclusive remedy in case a material defect in a Product is discovered and reported as required herein. RISCO’s obligation and this Limited Warranty are contingent upon the full payment by customer for such Product and upon a proven weekly testing and examination of the Product functionality.

**Limitations.** This Limited Warranty is the only warranty made by RISCO with respect to the Products. The warranty is not transferable to any third party. To the maximum extent permitted by applicable law, this Limited Warranty shall not apply and will be void if: (i) the conditions set forth above are not met (including, but not limited to, full payment by customer for the Product and a proven weekly testing and examination of the Product functionality); (ii) if the Products or any part or component thereof: (a) have been subjected to improper operation or installation; (b) have been subject to neglect, abuse, willful damage, abnormal working conditions, failure to follow RISCO's instructions (whether oral or in writing); (c) have been misused, altered, modified or repaired without RISCO's written approval or combined with, or installed on products, or equipment of the customer or of any third party; (d) have been damaged by any factor beyond RISCO's reasonable control such as, but not limited to, power failure, electric power surges, or unsuitable third party components and the interaction of software therewith or (e) any failure or delay in the performance of the Product attributable to any means of communication provided by any third party service provider, including, but not limited to, GSM interruptions, lack of or internet outage and/or telephony failure. BATTERIES ARE EXPLICITLY EXCLUDED FROM THE WARRANTY AND RISCO SHALL NOT BE HELD RESPONSIBLE OR LIABLE IN RELATION THERETO, AND THE ONLY WARRANTY APPLICABLE THERETO, IF ANY, IS THE BATTERY MANUFACTURER'S WARRANTY. RISCO does not install or integrate the Product in the end user's security system and is therefore not responsible for and cannot guarantee the performance of the end user's security system which uses the Product or which the Product is a component of.

This Limited Warranty applies only to Products manufactured by or for RISCO. Further, this Limited Warranty does not apply to any software (including operating system) added to or provided with the Products or any third-party software, even if packaged or sold with the RISCO Product. Manufacturers, suppliers, or third parties other than RISCO may provide their own warranties, but RISCO, to the extent permitted by law and except as otherwise specifically set forth herein, provides its Products "AS IS". Software and applications distributed or made available by RISCO in conjunction with the Product (with or without the RISCO brand), including, but not limited to system software, as well as P2P services or any other service made available by RISCO in relation to the Product, are not covered under this Limited Warranty. Refer to the Terms of Service at: [www.riscogroup.com/warranty](http://www.riscogroup.com/warranty) for details of your rights and obligations with respect to the use of such applications, software or any service. RISCO does not represent that the Product may not be compromised or circumvented; that the Product will prevent any personal injury or property loss by burglary, robbery, fire or otherwise, or that the Product will in all cases provide adequate warning or protection. A properly installed and maintained alarm may only reduce the risk of a burglary, robbery or fire without warning, but it is not insurance or a guarantee that such will not occur or will not cause or lead to personal injury or property loss. CONSEQUENTLY, RISCO SHALL HAVE NO LIABILITY FOR ANY PERSONAL INJURY, PROPERTY DAMAGE OR OTHER LOSS BASED ON ANY CLAIM AT ALL INCLUDING A CLAIM THAT THE PRODUCT FAILED TO GIVE WARNING.

EXCEPT FOR THE WARRANTIES SET FORTH HEREIN, RISCO AND ITS LICENSORS HEREBY DISCLAIM ALL EXPRESS, IMPLIED OR STATUTORY, REPRESENTATIONS, WARRANTIES, GUARANTEES, AND CONDITIONS WITH REGARD TO THE PRODUCTS, INCLUDING BUT NOT LIMITED TO ANY REPRESENTATIONS, WARRANTIES, GUARANTEES, AND CONDITIONS OF MERCHANTABILITY, FITNESS FOR A PARTICULAR PURPOSE, TITLE AND WARRANTIES AGAINST HIDDEN OR LATENT DEFECTS, TO THE EXTENT PERMITTED BY LAW. WITHOUT LIMITING THE GENERALITY OF THE FOREGOING, RISCO AND ITS LICENSORS DO NOT REPRESENT OR WARRANT THAT: (i) THE OPERATION OR USE OF THE PRODUCT WILL BE TIMELY, SECURE, UNINTERRUPTED OR ERROR-FREE; (ii) THAT ANY FILES, CONTENT OR INFORMATION OF ANY KIND THAT MAY BE ACCESSED THROUGH THE PRODUCT SHALL REMAIN SECURED OR NON DAMAGED. CUSTOMER ACKNOWLEDGES THAT NEITHER RISCO NOR ITS LICENSORS CONTROL THE TRANSFER OF DATA OVER COMMUNICATIONS FACILITIES, INCLUDING THE INTERNET, GSM OR OTHER MEANS OF COMMUNICATIONS AND THAT RISCO'S PRODUCTS, MAY BE SUBJECT TO LIMITATIONS, DELAYS, AND OTHER PROBLEMS INHERENT IN THE USE OF SUCH MEANS OF COMMUNICATIONS. RISCO IS NOT RESPONSIBLE FOR ANY DELAYS, DELIVERY FAILURES, OR OTHER DAMAGE RESULTING FROM SUCH PROBLEMS. RISCO WARRANTS THAT ITS PRODUCTS DO NOT, TO THE BEST OF ITS KNOWLEDGE, INFRINGE UPON ANY PATENT, COPYRIGHT, TRADEMARK, TRADE SECRET OR OTHER INTELLECTUAL PROPERTY RIGHT IN ANY EVENT RISCO SHALL NOT BE LIABLE FOR ANY AMOUNTS REPRESENTING LOST REVENUES OR PROFITS, PUNITIVE DAMAGES, OR FOR ANY OTHER INDIRECT, SPECIAL, INCIDENTAL, OR CONSEQUENTIAL DAMAGES, EVEN IF THEY WERE FORESEEABLE OR RISCO HAS BEEN INFORMED OF THEIR POTENTIAL.

## **Contacting RISCO**

RISCO Group is committed to customer service and Product support. You can contact us through our website ([www.riscogroup.com](http://www.riscogroup.com)) or at the following telephone and fax numbers:

### **United Kingdom**

Tel: +44-(0)-161-655-5500  
[support-uk@riscogroup.com](mailto:support-uk@riscogroup.com)

### **Italy**

Tel: +39-02-66590054  
[support-it@riscogroup.com](mailto:support-it@riscogroup.com)

### **Spain**

Tel: +34-91-490-2133  
[support-es@riscogroup.com](mailto:support-es@riscogroup.com)

### **France**

Tel: +33-164-73-28-50  
[support-fr@riscogroup.com](mailto:support-fr@riscogroup.com)

### **Belgium (Benelux)**

Tel: +32-2522-7622  
[support-be@riscogroup.com](mailto:support-be@riscogroup.com)

### **USA**

Tel: +1-631-719-4400  
[support-usa@riscogroup.com](mailto:support-usa@riscogroup.com)

### **China**

Tel: +86-755-82789285  
[support-cn@riscogroup.com](mailto:support-cn@riscogroup.com)

### **Israel**

Tel: +972-3-963-7777  
[support@riscogroup.com](mailto:support@riscogroup.com)

All rights reserved.

No part of this document may be reproduced in any form without prior written permission from the publisher.



© RISCO Group, 04/2022. All rights reserved.

5IN3006 B