



# USER MANUAL

EN

Edition: 1 from 13.02.2023

Supersedes edition:

## Power supplies HPSG3 series

Switch mode power supply units with battery backup

Grade 3



---

**GENERAL SAFETY RULES**

**Before installation, read the instruction manual to avoid errors that can damage the device and give you an electric shock.**

- Before installation, cut off voltage in 230 V power-supply circuit.
- To switch power off, use an external switch, in which distance between contacts of all poles in disconnection state is not less than 3mm.
- The shock protection circuit shall be done with a particular care: the yellow and green wire coat of the power cable should be connected to the terminal marked with the grounding symbol on the PSU enclosure. Operation of the PSU without the properly made and fully operational shock protection circuit is UNACCEPTABLE! It can cause damage to the equipment or an electric shock.
- Device should be transported without batteries. This has a direct impact on safety of user and device.
- Installing and connecting power supply must be carried out without batteries.
- When connecting batteries to power supply, pay particular attention to correct polarity. If necessary, it is possible to permanently disconnect battery from power supply systems by removing  $F_{BAT}$  fuse.
- Power supply is adapted to be connected to a power distribution network with an effectively earthed neutral conductor.
- Ensure a free, convection air flow around the enclosure. Do not cover ventilation openings.

---

**TABLE OF CONTENTS**

<b>1 FEATURES.....</b>	<b>4</b>
<b>2 TECHNICAL DESCRIPTION. ....</b>	<b>5</b>
2.1 GENERAL DESCRIPTION. ....	5
2.2 BLOCK DIAGRAM. ....	6
2.3 DESCRIPTION OF COMPONENTS AND POWER SUPPLY TERMINALS. ....	7
<b>3 INSTALLATION.....</b>	<b>9</b>
3.1 REQUIREMENTS. ....	9
3.2 INSTALLATION PROCEDURE. ....	9
3.3 PROCEDURE FOR CHECKING POWER SUPPLY MODULE ON INSTALLATION SITE. ....	10
<b>4 FUNCTIONS.....</b>	<b>11</b>
4.1 TECHNICAL OUTPUTS.....	11
4.2 COLLECTIVE FAILURE INPUT EXT IN. ....	12
4.3 OPTICAL INDICATION.....	13
4.4 INDICATION OPENING ENCLOSURE - TAMPER. ....	13
4.5 PSU OVERLOAD.....	13
<b>5 RESERVE POWER SUPPLY CIRCUIT.....</b>	<b>14</b>
5.1 RUNNING PSU ON BATTERY BACKUP.....	14
5.2 DEEP DISCHARGE BATTERY PROTECTION UVP. ....	14
5.3 BATTERY TEST.....	14
5.4 MEASUREMENT OF RESISTANCE OF BATTERY CIRCUIT.....	14
5.5 BATTERY OPERATING TEMPERATURE READINGS.....	14
5.6 STANDBY TIME. ....	14
<b>6 SPECIFICATIONS.....</b>	<b>15</b>
TABLE 4. ELECTRICAL PARAMETERS.....	15
TABLE 5. MECHANICAL PARAMETERS.....	16
TABLE 6. OPERATING PARAMETERS.....	17
TABLE 7. OPERATION SAFETY.....	17
<b>7 TECHNICAL INSPECTIONS AND MAINTENANCE.....</b>	<b>17</b>

## 1 Features.

- compliance with norm EN 50131-6:2017 in grade 1, 2, 3 and II environmental class
- compliance with norm EN60839-11-2:2015+AC:2015 and I environmental class
- supply voltage ~200 - 240 V
- DC 13,8 V or 27,6 V uninterruptible power supply
- powered by **17Ah - 65Ah** batteries
- high efficiency (up to 86%)
- available versions with current efficiencies  
13,8V: 3A, 5A, 10A  
27,6V 2A, 5A
- low ripple voltage
- microprocessor-based automation system
- measurement of resistance of battery circuit
- automatic temperature-compensated charging
- automatic battery test
- output voltage control
- battery circuit continuity control
- battery voltage control
- battery charging and maintenance control
- deep discharge battery protection (UVP)
- battery overcharge protection
- battery output protection against short circuit and reverse connection
- function START allows running PSU from battery power
- optical indication
- technical outputs OC type (open collector)
- collective failure input EXT IN
- EPS technical output indicating AC power loss
- PSU technical output indicating PSU failure
- APS technical output indicating battery failure
- protections:
  - SCP short circuit protection
  - OLP overload protection
  - OVP overvoltage protection
  - surge protection
  - antisabotage protection: unwanted enclosure opening – TAMPER
- convectional cooling
- warranty - 3 years from production date
- optional equipment (AWZ642)

## 2 Technical description.

### 2.1 General description.

Buffer power supplies have been designed in accordance with requirements of the (I&HAS) EN50131-6:2017 grade 1-3 and II environmental class and (KD) EN60839-11-2:2015+AC:2015 standard and I environmental class. Power supplies units are intended for an uninterrupted supply of alarm system devices requiring stabilized voltage of 12 or 24 V DC ( $\pm 15\%$ ).

Depending on a required protection level of the alarm system in the installation place, the PSU efficiency and the battery charging current should be set as follows:

Power supply model	Battery/charging current	Output current [A] depending on application PSU (according to EN50131-6)		
		Grade 1, 2 - standby time 12 h	* Grade 3 standby time 30 h	** Grade 3 standby time 60 h
<b>HPSG3-12V3A-C</b>	17Ah /0,8 A	1,39 A	0,54 A	0,25 A
<b>HPSG3-12V5A-C</b>	17Ah /0,8 A	1,39 A	0,54 A	0,25 A
<b>HPSG3-12V5A-D</b>	40Ah/1,8 A	3,3 A	1,30 A	0,64 A
<b>HPSG3-12V10A-E</b>	65Ah/2,6 A	5,4 A	2,1 A	1,0 A
<b>HPSG3-24V2A-C</b>	17Ah(x2) /0,8 A	1,4 A	0,5 A	0,24 A
<b>HPSG3-24V5A-D</b>	40Ah(x2) /1,8 A	3,3 A	1,3 A	0,63 A

\* if faults of primary source are reported to the ARC alarm receiving centre (in accordance with 9.2 EN50131-6)

\*\* if faults of primary source are not reported to the ARC alarm receiving centre (in accordance with 9.2 EN50131-6)

In case of lack of main power, battery back-up is activated immediately. Metallic enclosure with PSU (colour RAL 7016 - grey) can accommodate battery/batteries. It is equipped with a tamper switches signalling door opening and detaching from the surface.

## 2.2 Block diagram.

PSU has been manufactured based on a high-efficiency system of AC/DC converter. Applied microprocessor circuit is responsible for full diagnostics of PSU parameters and battery.

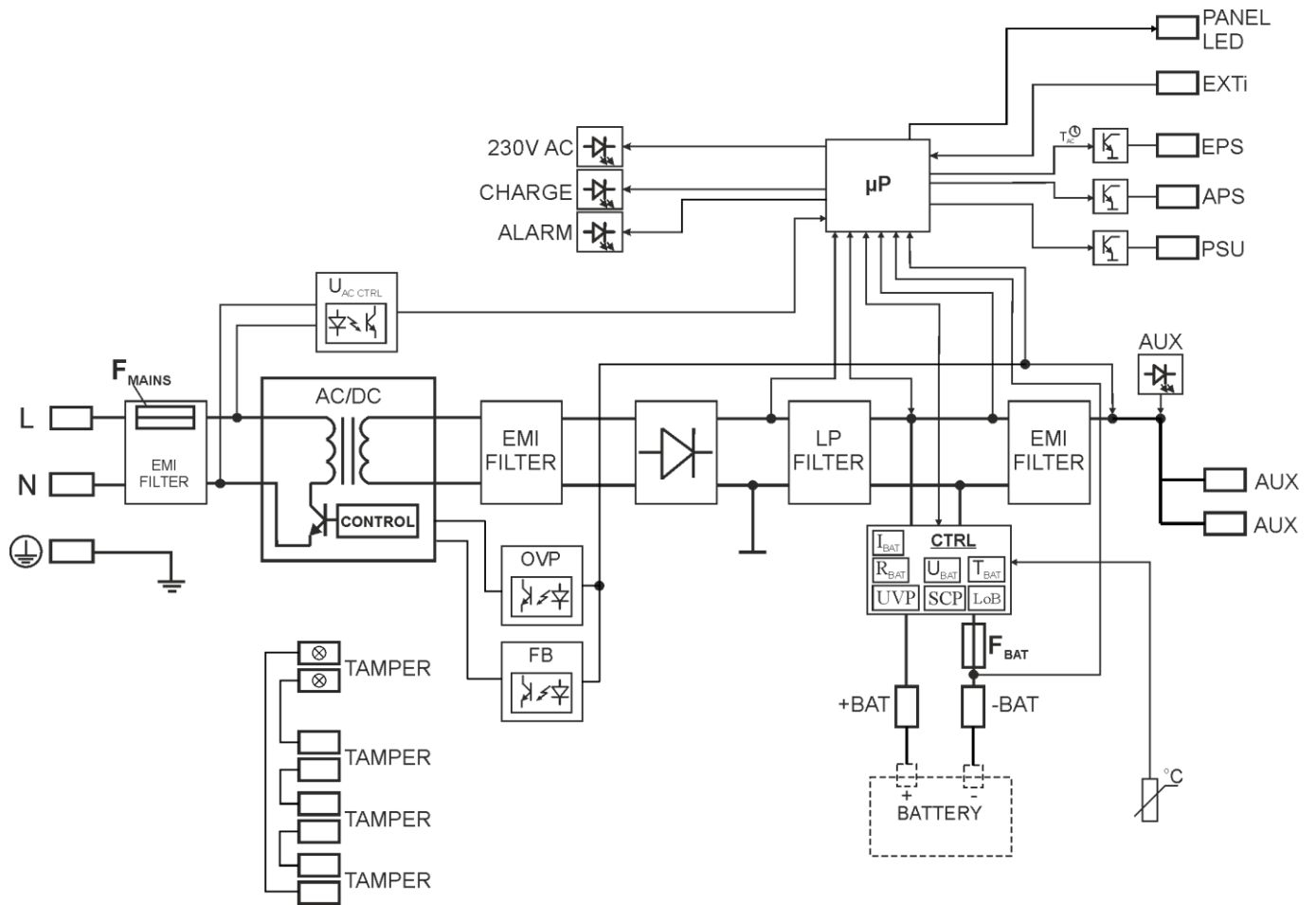

Fig. 1. Block diagram of PSU.

## 2.3 Description of components and power supply terminals.

Table 1. Elements of PSU PCB (Fig. 2).

Element no.	Description
①	230 V supply connector with a terminal for connection of a protective conductor
②	<b>START</b> – button (launching from battery)
③	Battery temperature <b>sensor</b>
④	<b>START</b> – button (launching from battery) Terminals: +AUX, -AUX – AUX power supply output ( - AUX=GND, +AUX= power supply output) EPS – technical output of AC network absence indication - OC type Open = AC power failure Close = AC supply - O.K. APS – technical output of battery failure Open = battery failure Close = battery O.K. PSU – technical output of PSU failure - OC type Open = failure Close = O.K. EXTi – input of external failure. Closed input = no indication Open input = failure +BAT- – terminals for connecting the battery TAMPER – antisabotage protection microswitch connector TEMP – input of battery temperature sensor
⑤	<b>Battery connectors</b> ; positive: +BAT = red, negative: - BAT = black
⑥	<b>PANEL</b> – connector to external LED indicators
⑦	<b>LEDs - optical indication:</b> <b>230 V AC</b> – indicates ~230 V power <b>CHARGE</b> – battery charging indication <b>ALARM</b> – collective fault indication
⑧	<b>F<sub>BAT</sub></b> – fuse in the battery circuit

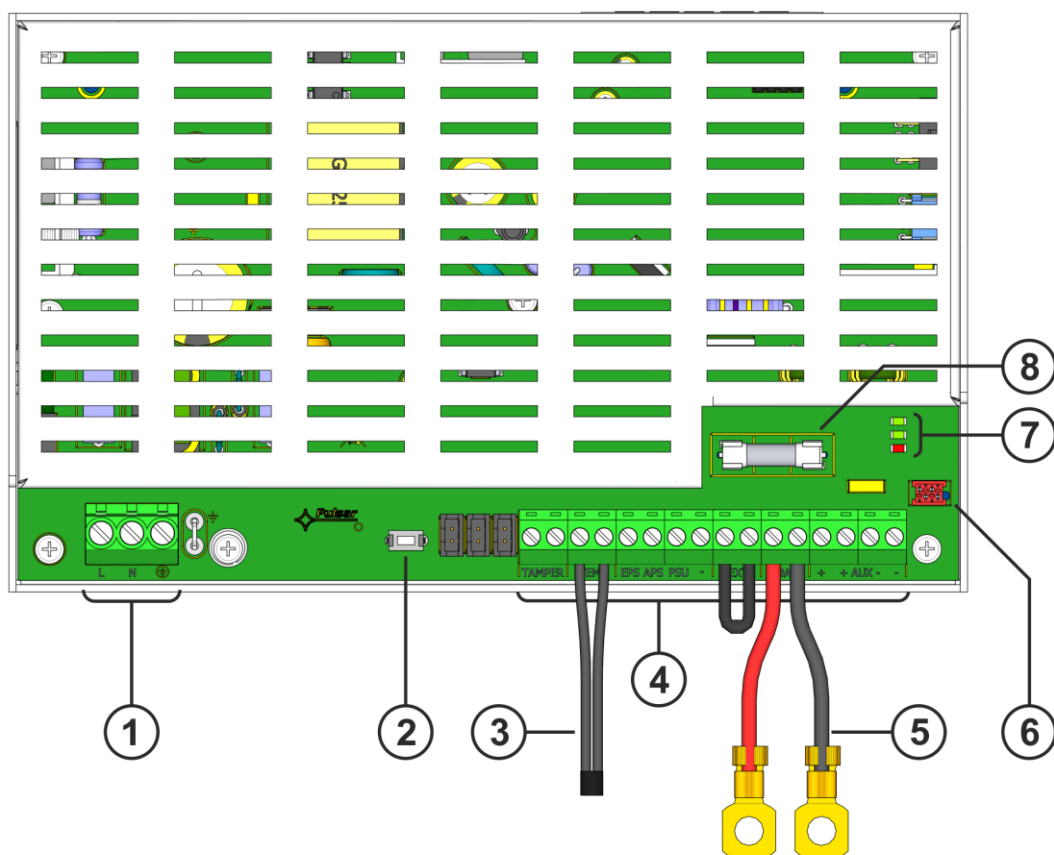

Fig. 2. View of power supply module.

**Table 2. Elements of PSU (see Fig. 3).**

Element no.	Description
①	PSU module (Tab. 1, Fig. 2)
②	Battery temperature sensor
③	Battery connectors; positive: BAT = red, negative: - BAT = black
④	A place for installation of additional communications modules
⑤	TAMPER; microswitch (contacts) of antisabotage protection (NC)
⑥	Fitting battery
⑦	Battery blocking plate

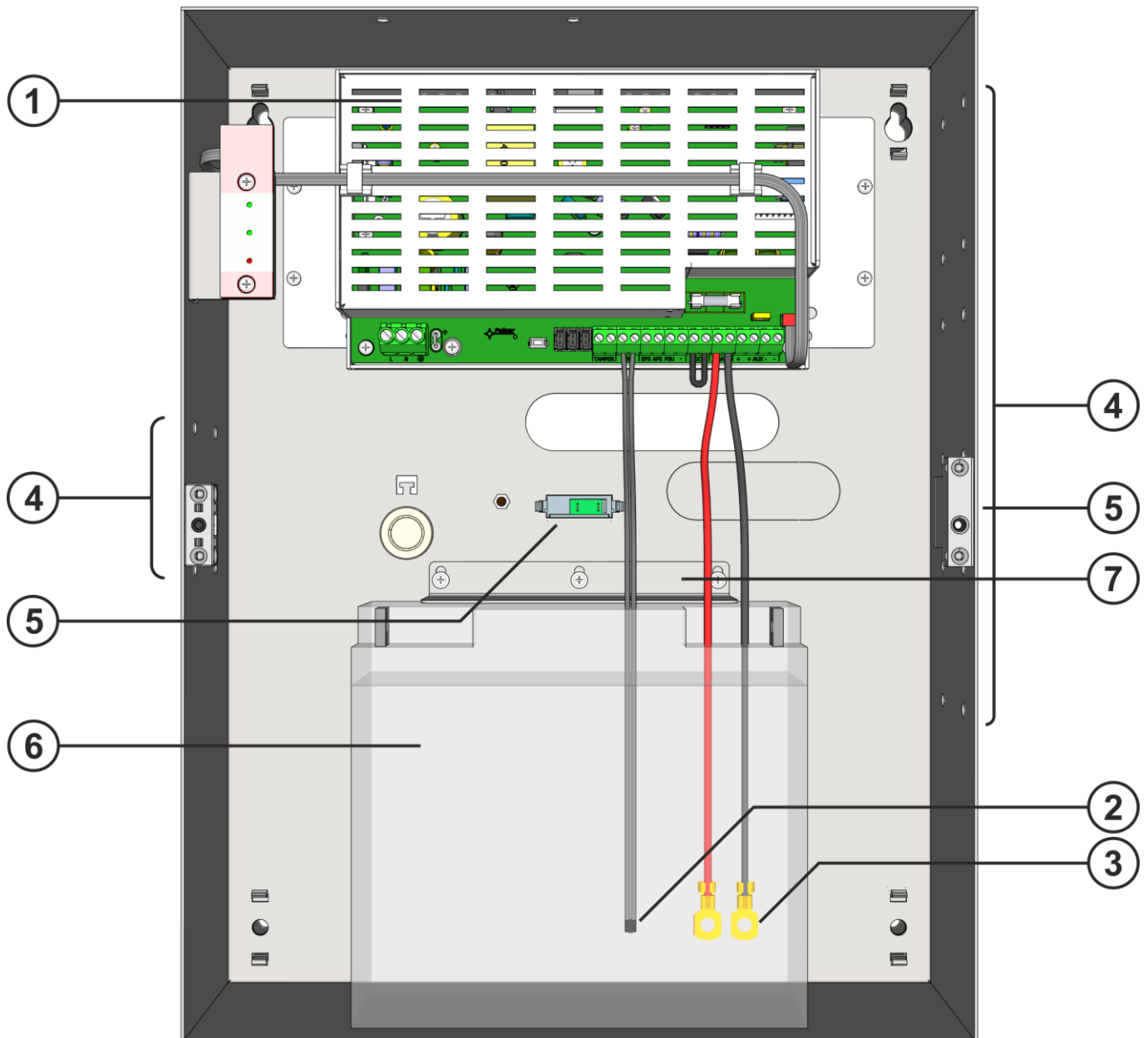

Fig. 3. View of PSU.



## 3 Installation.

### 3.1 Requirements.

Power supply units is to be mounted by a qualified installer, holding relevant permits and licenses (required in installation country) to connect (interfere) with ~230 V mains supply.

Because power supply units is designed for the continuous operation and is not equipped with ON/OFF switch, the power supply circuit should have the appropriate overload protection. Moreover, the user shall be informed about the method of unplugging (most frequently through separating and assigning an appropriate fuse in the fuse-box). The electrical system shall follow valid standards and regulations. The PSU shall work in a vertical position that guarantees sufficient convectional air-flow through ventilating holes of the enclosure.

As PSU cyclically runs a periodic battery test, during which resistance in battery circuit is measured, pay attention to proper connection of cables to terminals. Installation cables should be firmly connected to battery side terminals and to power supply connector. If necessary, it is possible to permanently disconnect battery from power supply systems by removing F<sub>BAT</sub> fuse.

### 3.2 Installation procedure.



#### CAUTION!

Before installation, cut off voltage in ~230 V power-supply circuit.  
To switch power off, use an external switch, in which distance between contacts of all poles in disconnection state is not less than 3mm.

It is required to install in the supply circuits, in addition to power supply, circuit breaker with 6 A nominal current.

1. Mount the PSU in a selected locatio.

Connect power cables ~230 V to L-N clips of PSU. Connect ground wire to clip marked by earth symbol

Use a three-core cable (with a yellow and green protection wire ) to make connection.

Wires should be deisolated to a length of 7mm.

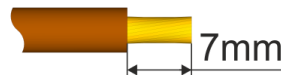

Shock protection circuit shall be done with a particular care: yellow and green wire coat of power cable should be connected to terminal marked with grounding

Operation of PSU without properly made and fully operational shock protection circuit is UNACCEPTABLE! It can cause damage to equipment or an electric shock.

2. Connect receivers' cables to AUX output terminals.
3. If needed, connect cables from devices to technical inputs and outputs:
  - **APS**; technical output of battery failure
  - **EPS**; technical output indication of 230 V power collapse (alarm control panel, controller, indicator, etc.).
  - **PSU**; technical output of collective failure of PSU
  - **EXTi**; input of external failure
  - **TAMPER**; contacts of antisabotage protection
4. Install battery/batteries in a designated area of enclosure. Connect batteries with PSU paying special attention to correct polarity and type of connections (Fig. 4):

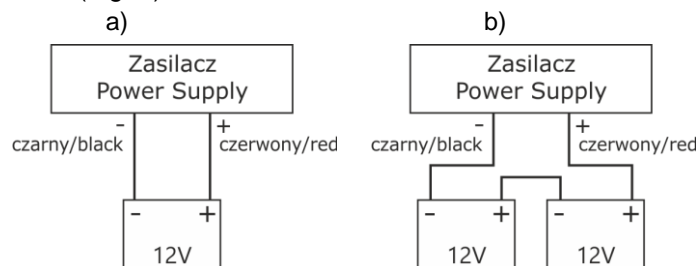

Fig. 4. Connecting batteries depending on voltage version of power supply:  
a) ) power supplies 12V version, b) power supplies 24V version

5. Screw terminals of temperature sensor to "Temp" terminals of PSU (figure 2, point 6). Attach sensor to battery, e.g. with adhesive tape. For the 27.6 V version, it is recommended to place sensor between batteries.
6. Switch on ~230 V supply. The corresponding LEDs on the power supply PCB should be ON: green 230 V AC and above AUX connectors.
7. Check current consumption of receivers, taking into account battery charging current, so as not to exceed total current efficiency of PSU (see section 2.1).
8. Once the tests and control operation have been completed, close the enclosure.

### 3.3 Procedure for checking power supply module on installation site.

1. Check indication displayed on printed circuit board of power supply:
  - a) 230 V AC LED should remain lit to indicate presence of mains supply voltage.
  - b) LED above AUX connectors lights up to indicate presence of output voltage.
2. Check output voltage after 230 V power failure.
  - a) Simulate lack of 230 V mains voltage by disconnecting main circuit breaker.
  - b) 230 V LED should go out.
  - c) LED above AUX connectors lights up to indicate presence of output voltage.
  - d) LED ALARM LED will start blinking.
  - e) EPS technical outputs will change status into opposite after time 11 s.
  - f) Turn on 230 V mains voltage again. Indication should return to initial status from point 1 after about 11 seconds.
3. Check whether lack of continuity in battery circuit is properly indicated.
  - a) During normal PSU operation (230 V mains voltage on), disconnect battery circuit by disconnecting  $F_{BAT}$  fuse.
  - b) Within 5 minutes PSU will start signalling a failure in battery circuit.
  - c) LED ALARM LED will start blinking. APS technical output will change status into opposite.
  - d)  $F_{BAT}$  fuse in battery circuit again.
  - e) Power supply should return to normal operation, indicating initial status, within 5 minutes after battery test is completed.

## 4 Functions

### 4.1 Technical outputs.

PSU module is equipped with indication outputs OC type changing status after a specified event:

- **EPS - output indicating 230 V power loss.**

Output indicates 230 V power loss. Under normal status – with 230 V supply on, output is closed. In case of power failure, PSU will switch output into open position after a time about 11 seconds.

- **APS - output indicating battery failure.**

The output indicates the PSU failure. Under normal status (during correct operation) the output is closed. In case of failure, the PSU will switch the output into the open position. Failure can be triggered by the following events:

- defective or low battery
- battery voltage below 23 V or 11,5 V (depending on voltage version of power supply) during battery operation
- battery fuse failure
- no continuity in the battery circuit

- **PSU - output indicating PSU failure.**

The output indicates the PSU failure. Under normal status (during correct operation) the output is closed. In case of PSU failure, it will switch into the open position. PSU failure can be caused by the following events:

- low  $U_{AUX}$  output voltage, less than 23,6 or 11,3 V – depending on voltage version of power supply
- high  $U_{AUX}$  output voltage, higher than 29,4 or 14,7 V – depending on voltage version of power supply
- high  $U_{aku}$  battery voltage, less than 28 or 14 V – depending on voltage version of power supply
- exceeding power supply output current
- battery charging circuit failure
- internal damage of PSU
- activation of the EXT IN input
- to high battery temperature ( $> 65^{\circ}\text{C}$ )
- temperature sensor failure,  $t < -20^{\circ}\text{C}$  or  $t > 80^{\circ}\text{C}$

The power supply technical outputs are open collector (OC) type, as shown schematically below.

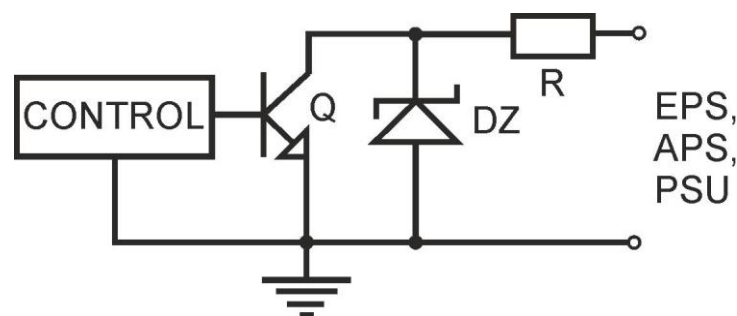

Fig. 5. Electrical diagram of technical outputs.

If it is necessary to use technical relay outputs, the AWZ642 relay module should be used.

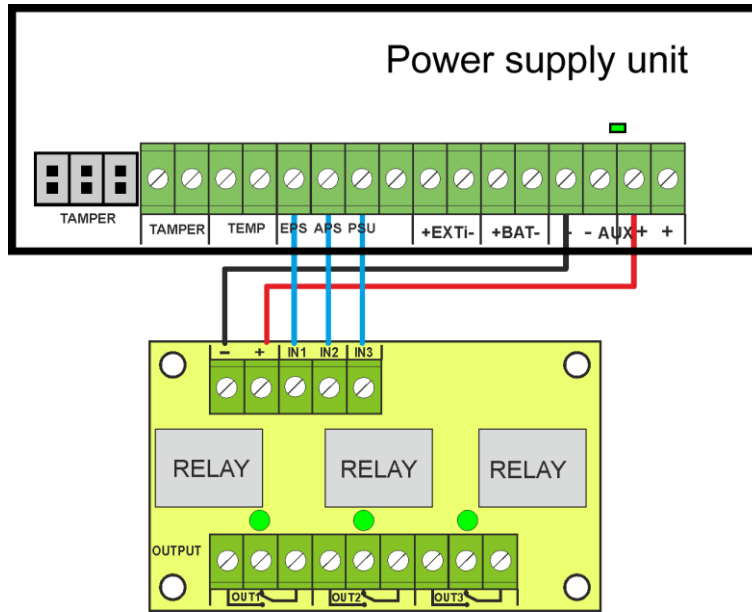

Fig. 6. Connection of the HPSG3 power supplies with the AWZ642 relay module.

#### 4.2 Collective failure input EXT IN.

EXT IN (external input) technical input indicating collective failure is intended for additional, external devices that generate failure signal. The voltage appearing at the EXT IN input will trigger PSU failure, storing the information about the event in the internal memory and sending the signal about the failure to the PSU output.

The connection of external devices to the EXT IN input is shown in the electrical diagram below. OC outputs (open collector) or relay outputs can be used as the source of the signal.

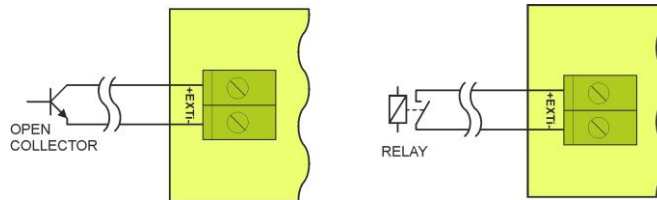

Fig. 7. Examples of connections.

The EXT IN input has been adjusted to work with fuse modules generating a failure signal in case of blown fuse in any of output sections (e.g. AWZ536). To guarantee a correct cooperation between the fuse module and the EXT IN input, the connections shall be made as presented in the diagram below.

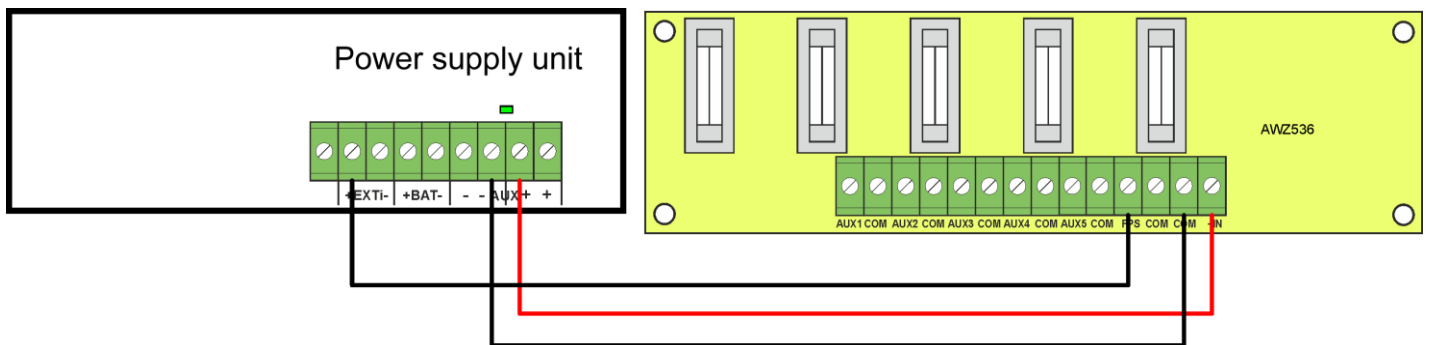

Fig. 8. Example of a connection with fuse module AWZ536.

### 4.3 Optical indication

PSU is equipped with LEDs on PCB indicating PSU operation status:

- 230V AC** ■ Indicating presence of ~230 V mains supply
- CHARGE** ■ Battery charging indication
- ALARM** ■ Collective fault indication

Optical indication on the front panel of power supply

Indicating presence of ~230 V mains supply

Indicating power at AUX output

Collective fault indication



ALARM LED flashes specified number of times to indicate failure code according to table below. If PSU has several failures at the same time, they are all indicated consecutively.

**Table 3. Coding of PSU failure by number of ALARM LED flashes on PCB of PSU.**

Failure description	Number of flashes
F01 – AC power loss	1
F04 – Output overload	2
F05 – Undercharged battery	3
F06 – High AUX1 voltage	4
F08 – Charging circuit failure	5
F09 – Low AUX1 voltage	6
F10 – Low battery voltage	7
F12 – External input EXTi	8
F14 – Temperature sensor failure	9
F15 – High battery temperature	10
F16 – No battery	11
F17 – Battery fail	12
F30 – PSU overload	13
F51 – Service code	14
F52 – Service code	15

### 4.4 Indication opening enclosure - TAMPER.

PSU is fitted with tamper microswitches indicating enclosure opening and detaching from surface.

Contacts of microswitches are normally closed, and their wires must be connected to input of control panel, etc.

### 4.5 PSU overload.

PSU is equipped with output overload protection circuit. If rated current of PSU is exceeded, microprocessor will switch to specially implemented procedure and signal failure on PSU output and ALARM LED on PCB. Depending on duration and level of PSU overload, microprocessor may put PSU into battery operation mode. After overload has stopped, PSU will resume correct operation.

An overload status of PSU is indicated by changing status of PSU technical output and blinking of ALARM LED on PCB.

## 5 Reserve power supply circuit.

PSU is fitted with circuits: charging and battery control whose main task is to monitor state of battery and connections in its circuit.

If controller detects a power failure in battery circuit, appropriate indication and change of APS technical output.

### 5.1 Running PSU on battery backup.

PSU has been fitted with a button on PCB to enable activate battery operation of PSU if required.

**Activation of PSU from battery:** to do that, press and hold the **START** button on the unit board for 1 second.

### 5.2 Deep discharge battery protection UVP.

PSU is fitted with disconnection system and battery discharge indication. During battery operation, lowering voltage below 10 V +/-0.2 V (20 V±0.2 in 27.6 V version) will disconnect battery within a few seconds.

Batteries are reconnected to power supply unit automatically once ~230 V mains supply is restored.

### 5.3 Battery test.

The PSU runs dynamic battery test every 5 minutes, temporarily switching the receivers to the battery operation mode. During testing, the control unit of the PSU measures the electrical parameters according to the implemented measuring method.

Negative test result will occur as soon as continuity of battery circuit is broken, or if voltage drops below 12 V or 24 V (depending on version of PSU).

Battery test function will also be automatically blocked if the PSU is in a working mode in which running of the battery test would not be possible. This condition occurs, for example, during battery operation or when PSU is overloaded.

### 5.4 Measurement of resistance of battery circuit.

PSU is checking resistance in battery circuit.

During measurement, PSU driver takes into account key parameters in circuit, and once limit value of 300m ohms is exceeded for 13,8 V version or 350 mΩ for 27,6 V version, a failure is indicated.

A failure may indicate considerable wear or loose cables connecting batteries.

### 5.5 Battery operating temperature readings.

Temperature measurement and compensation of battery charging voltage can extend life of batteries.

PSU has a temperature sensor to monitor temperature parameters of installed batteries. Attach sensor to battery, e.g. with adhesive tape. For the 27.6V version, it is recommended to place sensor between batteries. Be careful not to damage sensor when moving batteries.

### 5.6 Standby time.

Battery-assisted operating depends on battery capacity, charging level and load current. To maintain an appropriate standby time, current drawn from the PSU in battery mode should be limited.

Power supply model	Battery/charging current	Output current [A] depending on application PSU (according to EN50131-6)		
		Grade 1, 2 - standby time 12 h	* Grade 3 standby time 30 h	** Grade 3 standby time 60 h
HPSG3-12V3A-C	17Ah /0,8 A	1,39 A	0,54 A	0,25 A
HPSG3-12V5A-C	17Ah /0,8 A	1,39 A	0,54 A	0,25 A
HPSG3-12V5A-D	40Ah/1,8 A	3,3 A	1,30 A	0,64 A
HPSG3-12V10A-E	65Ah/2,6 A	5,4 A	2,1 A	1,0 A
HPSG3-24V2A-C	17Ah /0,8 A	1,4 A	0,5 A	0,24 A
HPSG3-24V5A-D	40Ah/1,8 A	3,3 A	1,3 A	0,63 A

\* if faults of primary source are reported to the ARC alarm receiving centre (in accordance with 9.2 EN50131-6)

\*\* if faults of primary source are not reported to the ARC alarm receiving centre (in accordance with 9.2 EN50131-6)

Depending on a required protection level of the alarm system in the installation place, the PSU efficiency and the battery charging current should be set as follows:

Output current PSU can be calculated from formula:

$$I_{WY} = Q_{AKU} / T - I_z$$

where:

$Q_{AKU}$  – minimum battery capacity [Ah]

$I_z$  – PSU current consumption (including optional modules) [A] (Table 4)

$T$  – standby time (12, 30 or 60 h)

## 6 Specifications.

Electrical parameters (tab. 4).

Mechanical parameters (tab. 5).

Operation safety (tab. 6).

**Table 4. Electrical parameters.**

	HPSG3-12V3A-C	HPSG3-12V5A-C	HPSG3-12V5A-D	HPSG3-12V10A-E	HPSG3-24V2A-C	HPSG3-24V5A-D
PSU type EN 50131-6	A, degree of protection 1 – 3, II environmental class					
Supply voltage	~200 - 240 V					
Power frequency	50/60 Hz					
Current consumption	0,52 A	0,77 A		1,33 A	0,71 A	1,32 A
Output power PSU	48 W	76 W		138 W	69 W	138 W
Efficiency	81%	82%		85%	83%	86%
Output voltage ( $T_A = 20\text{ }^\circ\text{C}$ )	11 V-13,8 V DC – buffer operation 10 V-13,8 V DC – battery-assisted operation				22 V-27,6 V DC – buffer operation 20 V-27,6 V DC – battery-assisted operation	
Total output current with charging	3,5 A	5,5 A	5,5 A	10 A	2,5 A	5 A
Output current	2,7A	4,7A	3,7A	7,4A	1,7A	3,2A
Battery capacity	17.. 20 Ah	17.. 20 Ah	40.. 45 Ah	65 Ah	17..20 Ah	40.. 45 Ah
Battery charging current	0,8 A	0,8 A	1,8 A	2,6 A	0,8 A	1,8 A
Ripple voltage	50 mV p-p	50 mV p-p	50 mV p-p	80 mV p-p	50 mV p-p	50 mV p-p
Current consumption by PSU during battery-assisted operation	35 mA	35 mA	35 mA	35 mA	45 mA	45 mA
Coefficient of temperature compensation of battery voltage	-18 mV/ $^\circ\text{C}$ (-5 $^\circ\text{C}$ -40 $^\circ\text{C}$ )				-36 mV/ $^\circ\text{C}$ (-5 $^\circ\text{C}$ - 40 $^\circ\text{C}$ )	
Low battery voltage indication	$U_{bat} < 11,5\text{ V}$ , during battery operation				$U_{bat} < 23\text{ V}$ , during battery operation	
Over voltage protection OVP	$U > 16\text{ V} \pm 1\text{ V}$ , automatic recovery				$U > 32\text{ V} \pm 2\text{ V}$ , automatic recovery	
Short-circuit protection SCP	Glass fuse $F_{BAT}$ (in case of a failure, fuse-element replacement required)					
Overload protection OLP	105-150% PSU power, automatically recovered					

<b>Battery circuit protection SCP and reverse polarity connection</b>	Glass fuse $F_{BAT}$ (in case of a failure, fuse-element replacement required)					
<b>Deep discharge protection UVP</b>	10 V +/- 0,3 V			20 V +/- 0,6 V		
<b>Technical outputs:</b> - EPS; output indicating AC power failure	- OC type: 50 mA max. normal status: L (0 V) level, failure: hi-Z level, time lag: 11 s.					
<b>Technical outputs:</b> - APS; output indicating battery failure - PSU; output indicating PSU failure	OC type: 50 mA max. normal status: L (0 V) level, failure: hi-Z level.					
<b>Technical outputs:</b> - EXTi; input of external failure	Closed input – no indication Open input – alarm					
<b>Fuse <math>F_{BAT}</math></b>	F5A/250V	T6,3A/250V	T6,3A/250V	T10A/30V	F4A/250V	T5A/30V

**Table 5. Mechanical parameters.**

	<b>HPSG3-12V3A-C</b>	<b>HPSG3-12V5A-C</b>	<b>HPSG3-12V5A-D</b>	<b>HPSG3-12V10A-E</b>	<b>HPSG3-24V2A-C</b>	<b>HPSG3-24V5A-D</b>
Enclosure dimensions (WxHxD) [ $\pm 2$ mm]	314x408x110	314x408x110	314x408x190	414x407x190	314x408x190	414x408x190
Fixing (WxH)	277x355	277x355	277x355	377x355	277x355	377x355
Space for battery (WxHxD)	304x166x94	304x166x94	304x172x172	404x178x172	304x172x172	404x178x172
Net/gross weight [kg]	5,9/6,3	6,1/6,5	8,3/8,7	10,8/11,5	8,3/8,7	10,8/11,5
Terminals	Battery outputs BAT: $\Phi 6$ (M6-0-2,5)					
	Mains supply: $\Phi 0,41-2,59$ (AWG 26-10), 0,5-4mm <sup>2</sup> Outputs: $\Phi 0,51-2,05$ (AWG 24-12), 0,5-2,5mm <sup>2</sup>					
Notes	Convictional cooling					

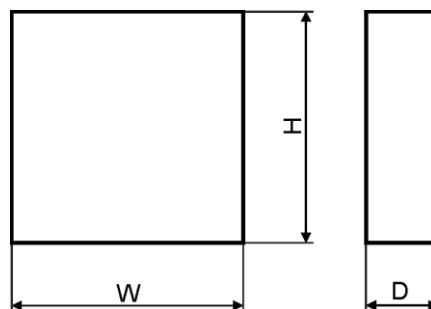

Fig. 9. Dimensions power supply.



**Table 6. Operating parameters.**

Environmental Class EN 50131-6	II
Environmental Class EN 60839-11	I (first)
Operating temperature	-10°C...+40°C
Storage temperature	-20°C...+60°C
Relative humidity	20%...90%, without condensation
Sinusoidal vibrations during operation:	According to PN-EN 50130-5
Impulse waves during operation	According to PN-EN 50130-5
Direct insolation	unacceptable
Vibrations and impulse waves during transport	According to PN-83/T-42106

**Table 7. Operation safety.**

Protection class EN 62368-1	I (first)
Protection grade EN 60529	IP44
Electrical strength of insulation: - between input and output circuits of PSU - between input circuit and protection circuit - between input circuit and output or protection circuit	4000 V DC 2500 V DC 500 V DC
Insulation resistance: - between input circuit and output or protection circuit	100 MΩ, 500 V DC

## 7 Technical inspections and maintenance.

Technical inspections and maintenance can be performed after disconnecting the power supply from the power network. The PSU does not require performing any specific maintenance measures, however, in the case of significant dust rate, its interior is recommended to be cleaned with compressed air. In the case of a fuse replacement, use a replacement of the same parameters.

Technical inspections should be carried out not less frequently than once per year. During the inspection, check batteries and run battery test.

4 weeks after installation, re-tighten all threaded connections Fig. 2 [1], [2].



### WEEE MARK

According to the EU WEE Directive – It is required not to dispose of electric or electronic waste as unsorted municipal waste and to collect such WEEE separately.



**CAUTION!** The power supply module unit is adapted for a sealed lead-acid battery (SLA). After the operation period it must not be disposed of but recycled according to the applicable law.

**Pulsar sp. j.**  
**Siedlec 150, 32-744 Łapczyca, Poland**  
**Tel. (+48) 14-610-19-45**  
**e-mail: [sales@pulsar.pl](mailto:sales@pulsar.pl)**  
**[http:// www.pulsar.pl](http://www.pulsar.pl)**

