



PSB-1552455
PSB 27,6V/5,5A enclosed switch
mode buffer power supply



Edition: 6 from 01.03.2018
 Supercedes edition: 5 from 20.06.2017

EN

Features of the power supply:

- DC 27,6V/5,5A uninterruptible power supply*
- wide AC input voltage range 176÷264V
- high efficiency 84%
- controlling of battery charging and maintaining
- protecting of battery against excessive discharging (UVP)
- battery charging current 0,5A/2A, changed by jumper
- additional accessories: automation module MPSB24 (technical outputs):
 - EPS technical output indicating AC power loss
 - PSU technical output indicating PSU failure
 - LoB technical output indicating battery low voltage
- battery output is full protected against short-circuit and reverse connection
- LED optical signalisation
- protections:
 - short-circuit protection SCP
 - over voltage protection OVP
 - surge protection
 - overload protection OLP
- warranty – 2 year from the production date

1. Technical description.

1.1. General description.

Buffer-type power supply units are intended for continuous power supply to devices that require stabilised voltage of **24V DC (+/-15%)**. The power supply provides a voltage of **U=27,6V DC** with an output current of:

- 1. Output current of 5A + 0,5A battery charging*.**
- 2. Output current of 3,5A + 2A battery charging*.**

Total device current + battery: 5,5A max.*

In case of power voltage decay, prompt switching to battery supply occurs. The power supply unit is protected against a short circuit, an overload, a surge or over voltage protection.

1.2. Technical parameters.

Supply voltage	176÷264V AC
Current consumption	1,4A@230VAC max.
Supply power	155W max.
Efficiency	84%
Output voltage	22V÷ 27,6V DC – buffer operation 19V÷ 27,6V DC – battery operation
Output current t_{AMB}<30°C	5A + 0,5A battery charging - see chart 1 3,5A + 2A battery charging - see chart 1
Output current t_{AMB}=40°C	3,3A + 0,5A battery charging - see chart 1 1,8A + 2A battery charging - see chart 1
Voltage adjustment range	24÷28V DC
Ripple voltage	150mV p-p max.
Battery charging current	0,5A or 2A max.
Short-circuit protection SCP	electronic
Overload protection (battery) OLP	glass fuse
Surge protection	varistors
Overvoltage protection OVP	>32V (automatic recovery)
Excessive discharge protection UVP	U<19V (± 5%) – disconnection of battery

* See chart 1

Optical signalisation	green LED- presence of AC voltage
Output of optical signalization	LED AC- presence of AC voltage LED DC- presence of DC voltage on power supply output
Additional accessories	Module MPSB24 (technical outputs)
Operation conditions	2-nd enviromental class, temperature: -10 °C÷40 °C relative humidity 20%...90%, without condensation
Dimensions	L=199, W=110, H=50 [±2mm]
Net/gross weight	0,76kg / 0,82kg
Protection class EN 60950-1:2007	I (first) - requires a protective conductor (PE)
Connectors	power-supply: $\Phi 0,63 \pm 2,5$ I/O PCB: $\Phi 0,41 \pm 1,63$ battery output BAT: 6,3F-2,5/40cm, output of optical signalization: plug 3-pin 5 mm
Electrical strength of insulation: - between input (network) circuit and output circuits of power-supply (I/P-O/P) - between input circuit and PE protection circuit (I/P-FG) - between output circuit and PE protection circuit (O/P-FG)	3000 V/AC min. 1500 V/AC min. 500 V/AC min.
Insulation resistance: - between input circuit and output or protection circuit	100 M Ω , 500V/DC
Storage temperature	-20°C...+60°C
Vibrations and impulse waves during transport	according to PN-83/T-42106

1.3. Output current vs temperature.

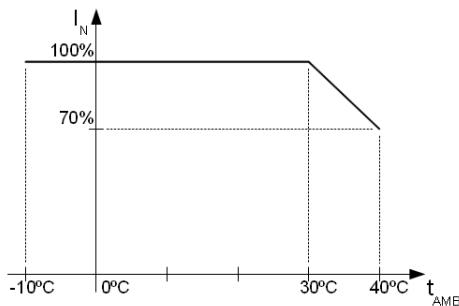

Chart 1.
Allowable output current from the power supply depending on ambient temperature.

2. Installation.

2.1. Requirements.

The buffer power supply shall be mounted by the qualified installer having appropriate (required and necessary for a given country) permissions and qualifications for connecting (operating) 230V/AC installations and low voltage installations. The device shall be mounted in closed rooms, according to the environment class II, of the normal air humidity (RH=90% max. without condensation) and the temperature within the range from -10°C to +40°C.

The power supply shall be mounted in a close casing (a cubicle, a terminal device) and in order to fulfill LVD and EMC requirements the rules for power-supply, encasing and shielding shall be observed according to application.

Due to the power supply design, the PE wire has to be connected to the corresponding connector of the supply unit. Operation without proper grounding of the power supply is not allowed!

Prepare the power supply loading balance before installation:

1. Output current of 5A + 0,5A battery charging*.
2. Output current of 3,5A + 2A battery charging*.

Total device current + battery: 5,5A. max.*

2.2. Installation procedure.

1. Before beginning installation, ensure that the power in the 230V AC power supply circuit is disconnected.
2. Install the unit in the previously selected place.
3. Connect the 230VAC power leads. Connect the PE cable (yellow-green) to an appropriate terminal on the power supply unit (marked with \perp).

* See chart 1



The circuit of the shock protection shall be performed with a particular care, i.e. the yellow and green protection wire of the power cable shall be connected from one side to the terminal marked by the symbol of \oplus in the casing of the power-supply. Operation of the power-supply without the properly made and fully operational circuit of the shock protection is UNACCEPTABLE! It can result in failure of devices and electric shock.

4. Connect load/loads to proper output connectors of the power supply (positive end is marked as +V, negative as -V).
5. Connect battery to the unit according marks (colors).
6. After the completion of tests and trial activation, close the housing, cabinet etc.

2.3. Description of terminals.

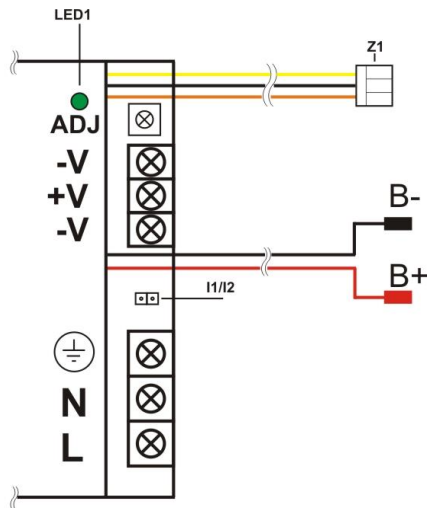





Fig 1. Description of terminals.

Elements/connectors [Fig.1]	Description
L, N, \oplus	L-N - input voltage connectors 230V AC, \oplus - protective conductor connector
-V	Power supply output (0V)
+V	Power supply output (+27,6V)
LED1	LED signals the presence of AC voltage
ADJ	Potentiometer - output voltage adjust
I1/I2	Jumper -battery charging current configuration:  Ibat =0,5A  Ibat =2A Legend:  jumper installed,  jumper removed
B+	Battery terminal- positive (+)
B-	Battery terminal- negative (-)
Z1	Connector of optical signalization

2.4. Dimensions and fitting of the PSB-1552455 power supply.

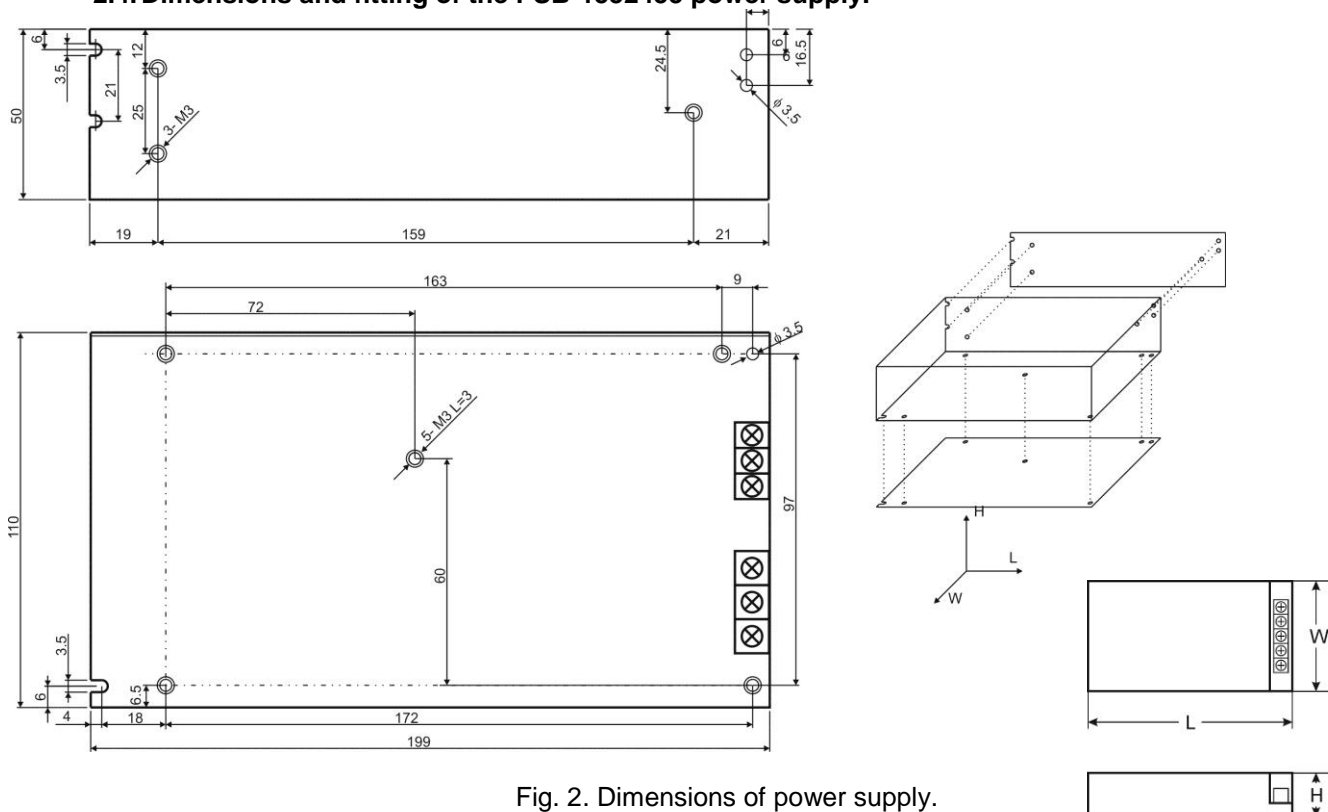







Fig. 2. Dimensions of power supply.

3. Cooperation with the MPSB24 automation module (option).

The MPSB24 automation module is intended for indicating the operating status of buffer power supplies, PSB 27,6V type. The PCB board features LEDs that indicate PSU operating status (presence of AC voltage, presence of DC voltage, battery voltage). The module is also equipped with technical outputs of: **EPS** - AC power loss, **PSU** - PSU failure, **LoB** - low battery voltage.

Element no.	Description
[1]	LED indicating presence of AC power
[2]	LED indicating presence of DC power
[3]	LED indicating correct battery voltage
[4]	EPS - AC absence technical output – relay type
[5]	PSU - output indicating DC absence/PSU failure – relay type
[6]	LoB - output indicating battery low voltage – relay type
[7]	EPS - AC absence technical output – OC type
[8]	PSU - output indicating DC absence/PSU failure - OC type
[9]	LoB - output indicating battery low voltage - OC type
[10]	V_{ADJ} - potentiometer, DC voltage adjustment
[11]	+V , -V - DC supply output
[12]	L-N 230V/AC power connector,  PE protection connector
[13]	Battery connectors: +BAT =red, - BAT = black
[14]	LED indication on the front panel
[15]	Battery charging current selection  $I_{bat} = 0,5$ A  $I_{bat} = 2$ A Legend:  jumper on  jumper off

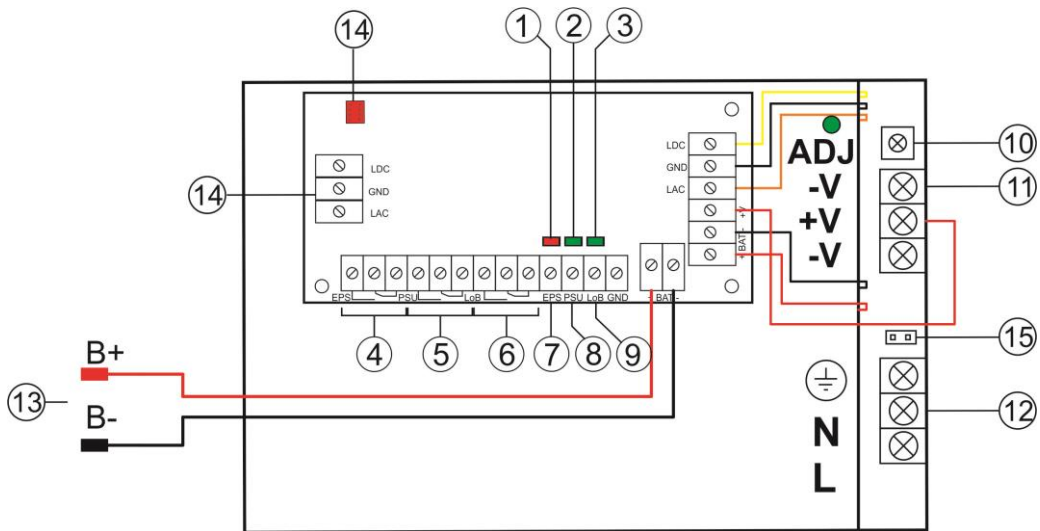

Fig. 3. The view of the PSU with the MPSB24 module.

4. Maintenance.

All maintenance procedures can be performed after the disconnection of the power supply from the electrical grid. The power supply does not require any special maintenance procedures, but in the case of significant dust accumulation, dusting using compressed air is recommended.

WEEE MARKING

According to the EU WEE Directive – It is required not to dispose of electric or electronic waste as unsorted municipal waste and to collect such WEEE separately.

Pulsar sp. j.

Siedlec 150, 32-744 Łapczyca, Polska
 Tel. (+48) 14-610-19-40, Fax. (+48) 14-610-19-50
 e-mail: biuro@pulsar.pl, sales@pulsar.pl
 http:// www.pulsar.pl, www.zasilacze.pl